

KENWOOD

KAC-PS300T KAC-PS200T

POWER AMPLIFIER ▶ Page 2-13

INSTRUCTION MANUAL

AMPLIFICATEUR DE PUISSANCE ▶ Page 14-25

MODE D'EMPLOI

AMPLIFICADOR DE POTENCIA ▶ Page 26-37

MANUAL DE INSTRUCCIONES

KENWOOD CORPORATION

**Take the time to read through this instruction manual.
Familiarity with installation and operation procedures will help
you obtain the best performance from your new power amplifier.**

For your records

Record the serial number, found on the back of the unit, in the spaces designated on the warranty card, and in the space provided below. Refer to the model and serial numbers whenever you call upon your KENWOOD dealer for information or service on the product.

Model KAC-PS300T/PS200T Serial number _____

Safety precautions

▲WARNING

Take the following precautions to prevent fire and avoid personal injury :

- When extending the battery cable, or ground cable, use 5mm² (AWG10) or larger automotive grade cable to avoid cable deterioration or damage to the covering.
- Check that no metal objects (coins, tools, etc.) are left inside the unit to avoid short circuits.
- If you smell or see smoke, turn the power off immediately and consult your Kenwood dealer.
- Do not touch the unit during use because the surface of the unit becomes hot and may cause burns if touched.

▲CAUTION

Take the following precautions to keep the unit in proper working order.

- Be sure the unit is connected to a 12V DC power supply with a negative ground connection.
- Do not open the top or bottom cover.
- Do not install the unit in places it is exposed to direct sunlight, high heat or humidity, water may splash over it, or dust exists.

NOTE

- If you have difficulty in installing this unit in your vehicle, contact your Kenwood dealer.

Cleaning the unit

- If the surface is dirty, wipe it clean with a silicon cloth or soft dry cloth with the power off.



▲CAUTION

Do not use hard cloths or paint thinner, alcohol, or other volatile solvents. These may damage external surfaces or remove indicator characters.

FCC WARNING

This equipment may generate or use radio frequency energy. Changes or modifications to this equipment may cause harmful interference unless the modifications are expressly approved in the instruction manual. The user could lose the authority to operate this equipment if an unauthorized change or modification is made.

Accessories

Part name	External View	Number of Items
Self-tapping screws (ø5 × 18mm)		4
Terminal cover (Power terminal)		1

Installation procedure

1. Remove the ignition key and disconnect the negative \ominus terminal of the battery to prevent short circuits.
2. Set the unit according to the intended usage.
3. Connect the input and output cables of the units.
4. Connect the speaker cables.
5. Connect the power cable, power control cable and grounding cable following this order.
6. Install the unit in the car.
7. Connect the negative \ominus terminal of the battery.

⚠CAUTION

- Be sure to turn the power off before changing the setting of any switch.
- If the fuse blows, check cables for shorts, then replace the fuse with one of the same rating.
- Check that no unconnected cables or connectors are touching the car body. Do not remove caps from unconnected cables or connectors to prevent short circuits.
- Connect the speaker cables to appropriate speaker connectors separately. Sharing the negative cable of the speaker or grounding speaker cables to the metal body of the car can cause this unit to fail.
- After installation, check that the brake lamps, wipers, and wipers work properly.

Installation

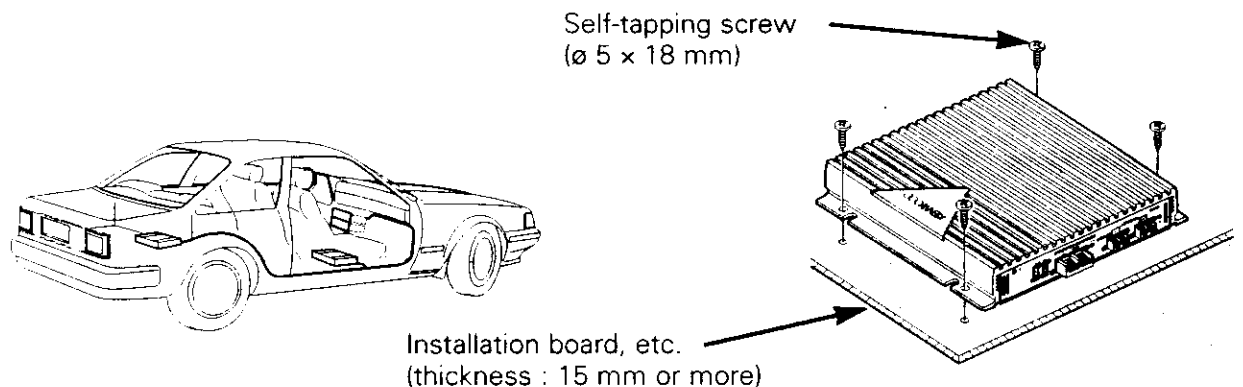

Since the power amplifier has no parts which require operation, it can be installed at a position away from the driver's seat without any hindrances.

As generally accepted positions for its installation, places such as inside the trunk, etc. can be considered.

⚠CAUTION

- Do not install the unit under the carpet. Otherwise heat build-up occurs and the unit may be damaged.
- Install this unit in a location which allows heat to easily dissipate.
Once installed, do not place any object on top of the unit.
- The KAC-PS300T has cooling fans to decrease the internal temperature. Be careful not to block the cooling fan openings when installing the unit. Blocking these openings will inhibit the cooling of the internal temperature and result in malfunction.
- After installing the unit, check to make sure that electrical equipment such as the brake lamps, turn signal lamps and windshield wipers operate normally.
- Install the unit securely in a location that does not interfere with driving.

Controls

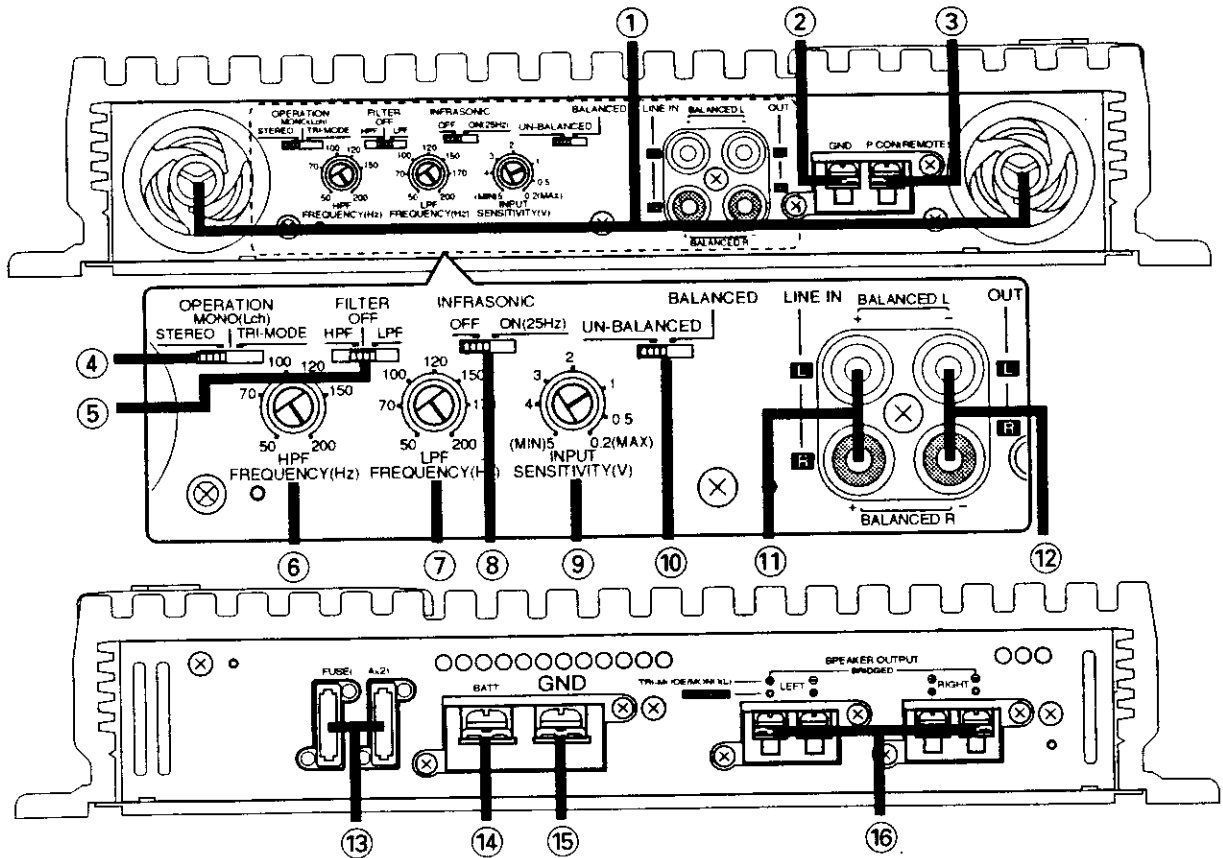

- ① **Cooling fans (KAC-PS300T only)**
Ventilation fans which cool the inside of the amplifier to reduce the temperature rise.
- ② **RCA cable ground lead terminal**
- ③ **Power control (REMOTE) lead terminal**
- ④ **OPERATION switch**
This switch is used to select the operation mode of the amplifier.
- **STEREO position:**
The amplifier functions as a stereo amp which boosts the left and right input signals independently.
- CAUTION**
- Do not connect the speaker outputs in a bridge connection.
- **MONO (Lch) position:**
The amplifier functions as a monaural amp which boosts only the left channel input signal.
- NOTE**
- The right channel input signal is not output.
- **TRI-MODE position:**
The amplifier functions as a stereo amp which can output a bridge-connected output (which is doubled).

- ⑤ **FILTER switch**
This switch allows to apply high-pass or low-pass filtering to the speaker outputs.
- **HPF (High-Pass Filter) position:**
The filter outputs the band of higher frequencies than the frequency set with the HPF FREQUENCY control.
 - **OFF position:**
The entire bandwidth is output without filtering.
 - **LPF (Low-Pass Filter) position:**
The filter outputs the band of lower frequencies than the frequency set with the LPF FREQUENCY control.
The speaker output is automatically turned monaural (L+R) and the bass boost function is activated.
- ⑥ **HPF FREQUENCY control**
Sets the cutoff frequency when the FILTER switch is set to HPF.
- ⑦ **LPF FREQUENCY control**
Sets the cutoff frequency when the FILTER switch is set to LPF.

⑧ **INFRASONIC FILTER switch**

When this switch is ON, the frequencies which are below the audible range and therefore inaudible are cut off so that the quality of the audible frequencies can be improved.

⑨ **INPUT SENSITIVITY control**

Adjust this control according to the pre-out level of the center unit connected to this amp.

NOTE

- Refer to "Specifications" on the center unit's instruction manual about the pre-out level.
- The input level of signals sent through balanced transmission is twice that of signals sent through unbalanced transmission. Therefore, be sure to decrease the input sensitivity (toward MIN.).

⑩ **BALANCE INPUT CHANGEOVER switch**

This switch selects between RCA terminal input and output.

To use LINE OUT, set this switch to the UN-BALANCED position.

To obtain a higher S/N ratio by connecting a commercially available balance converter, set this switch to the BALANCED position.

⑪ **LINE IN terminal**

RCA input terminal. It can be used by setting the BALANCE INPUT CHANGEOVER switch as follows:

When the switch is set to UN-BALANCED position:

These sockets are L and R LINE IN

When the switch is set to BALANCED position:

These sockets are L+ and R+ LINE IN

⑫ **OUT terminal**

RCA input/output terminal. It can be used by setting the BALANCE INPUT CHANGEOVER switch as follows:

When the switch is set to UN-BALANCED position:

These sockets are L and R LINE OUT

When the switch is set to BALANCED position:

These sockets are L- and R- LINE IN

⑬ **FUSE**

⑭ **BATTERY terminal**

⑮ **Ground terminal**

⑯ **SPEAKER OUTPUT terminals**

The speaker output signals vary depending on the OPERATION switch setting.

• **STEREO position:**



• **MONO (Lch) / TRI-MODE position:**

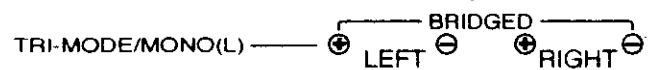

▲CAUTION

- The speaker used with the bridge connection should have an impedance of 4 ohms or more. Connecting a speaker with a lower impedance than 4 ohms may result in malfunction.
- The rated input of the speakers used should not be smaller than the rated output of the amplifier. Otherwise malfunction may result. Be specially careful when using the bridge connection.

Balanced transmission

The balanced signal transmission is resistant to noise because it transmits an audio signal by dividing it into hot (+) and cold (-) symmetrical signal with the hot signal).

Connection

Power and Speakers cable connection

Power terminal

Pass battery and ground cables through supplied terminal cover and connect to respective terminals. After completing connections, fasten terminal cover over terminal bracket.

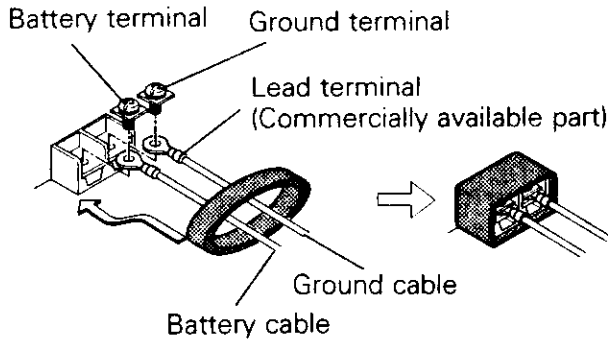

Speaker output cable terminal

Connect the speaker output cables to these terminals.

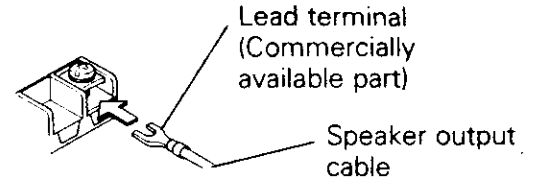

Operation switch	Speaker terminal polarity
STEREO	LEFT ⊖ RIGHT ⊕
MONO (Lch) / TRI-MODE	BRIDGED LEFT ⊖ RIGHT ⊕

⚠ WARNING

To prevent fire caused by a short in the wiring, connect a fusible link or breaker nearby the battery's positive terminal.

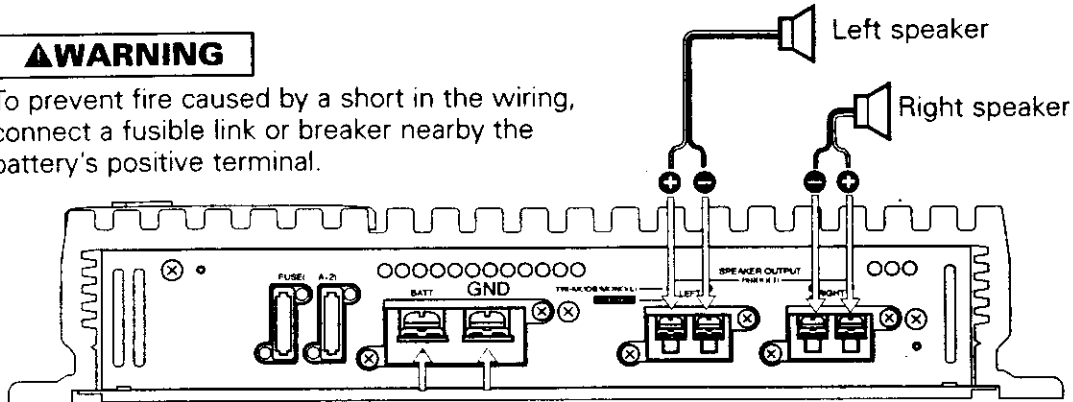

NOTE

Connect the ground cable to a metal part of the car chassis that acts as an electrical ground passing electricity to the battery's negative ⊖ terminal. Do not turn the power on if the ground cable is not connected.

Terminal cover

Battery cable

Ground cable

If a buzzing noise is heard from the speakers when the engine is running, connect a line noise filter (optional) to each of the battery cable.

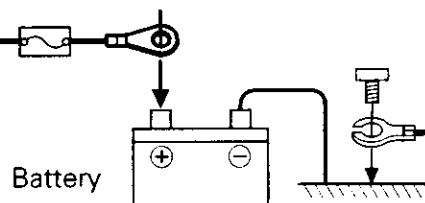

RCA cable connection

LINE IN and OUT terminals

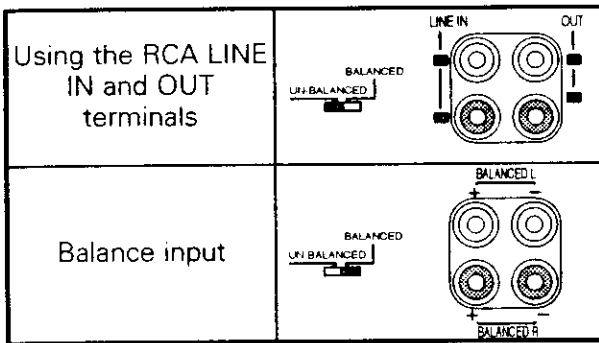

NOTE

Use the optional balanced transmission cable (KDC-600) when balanced signal connection is required.

RCA cable ground lead terminal

When using an RCA cable with a ground lead attached, connect the ground lead to this terminal.

CAUTION

Do not use this terminal for power source grounding. This unit will be damaged if the power source grounding wire is connected to this terminal.

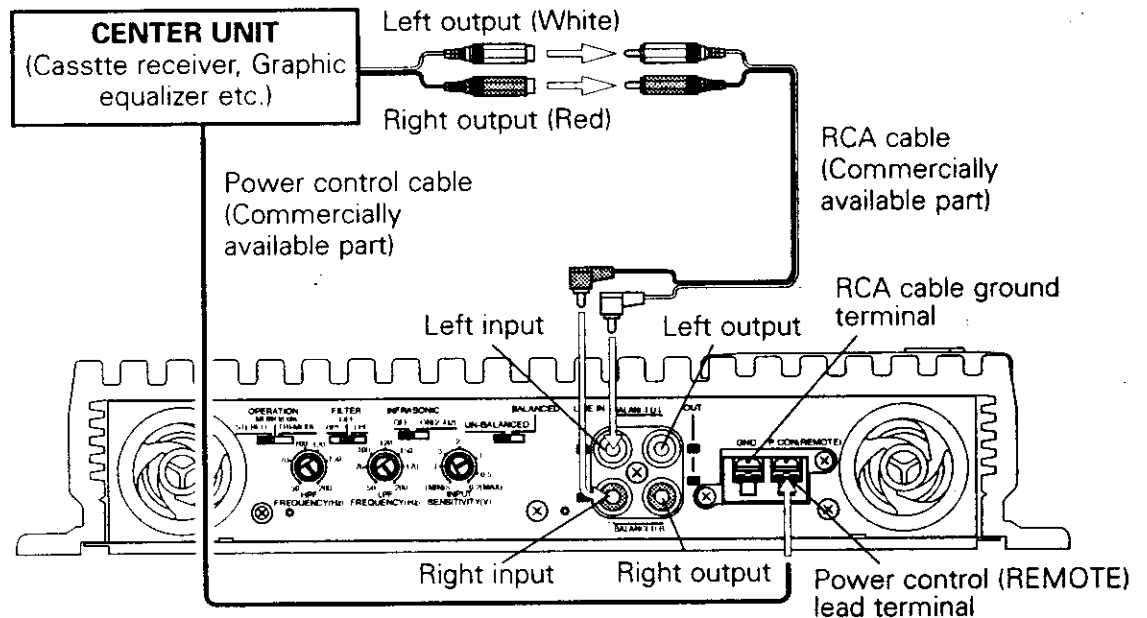
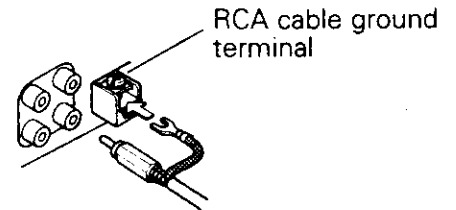

Power control lead terminal

Connect the Center units's power control lead from the center unit.

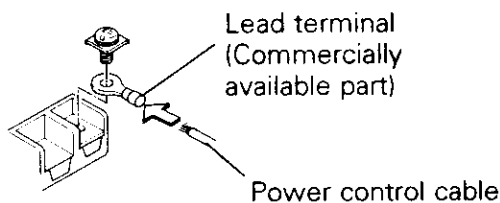

System examples

By combining the switches and functions of the KAC-PS300T/PS200T, you can implement a wide range of audio system configurations.

■ Full-range 2-channel system (un-balanced)

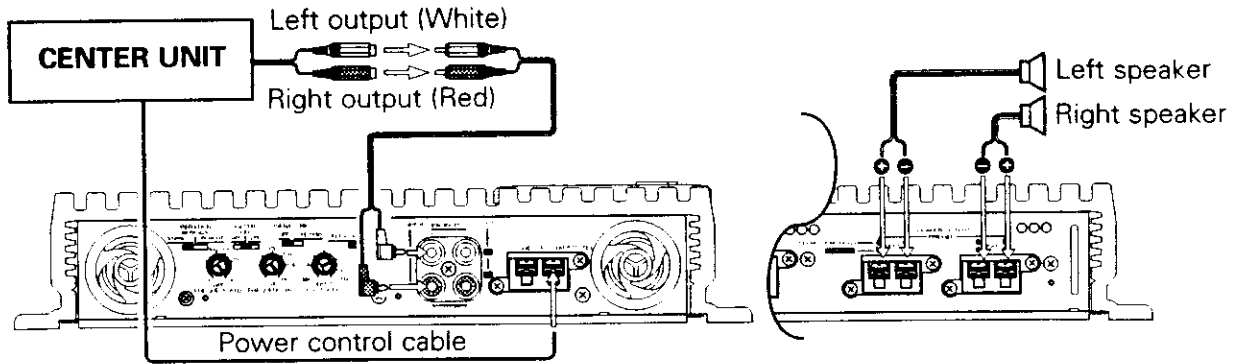

Switch setting

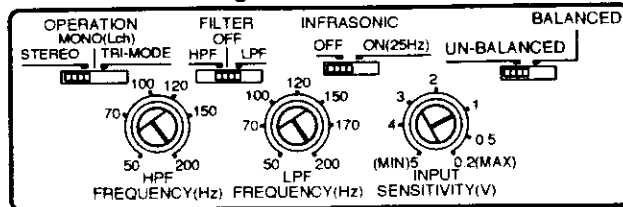

■ High-pass (80 Hz) + Low-pass (80 Hz) multi system

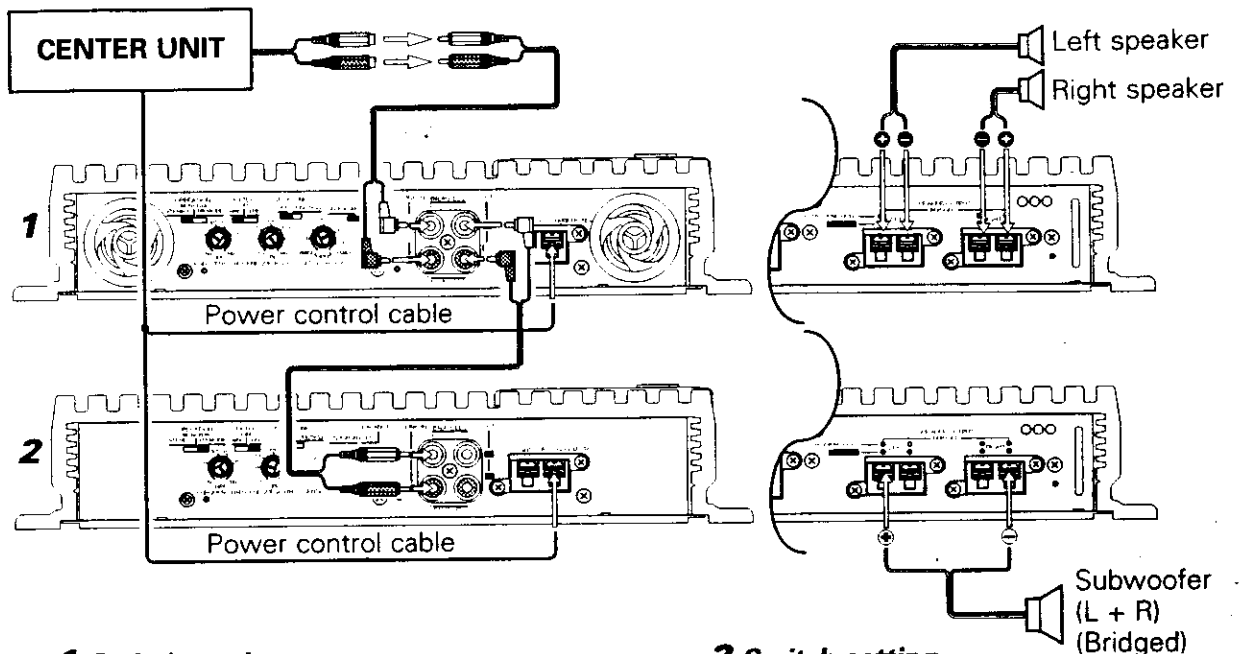

1 Switch setting

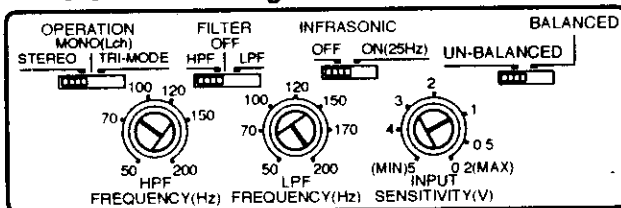

2 Switch setting

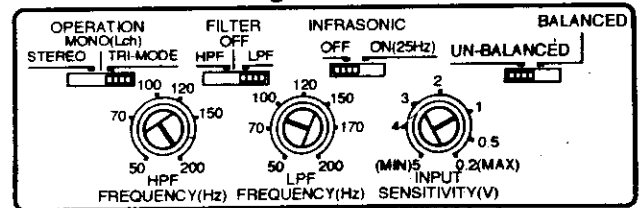

■ Subwoofer (110 Hz) system

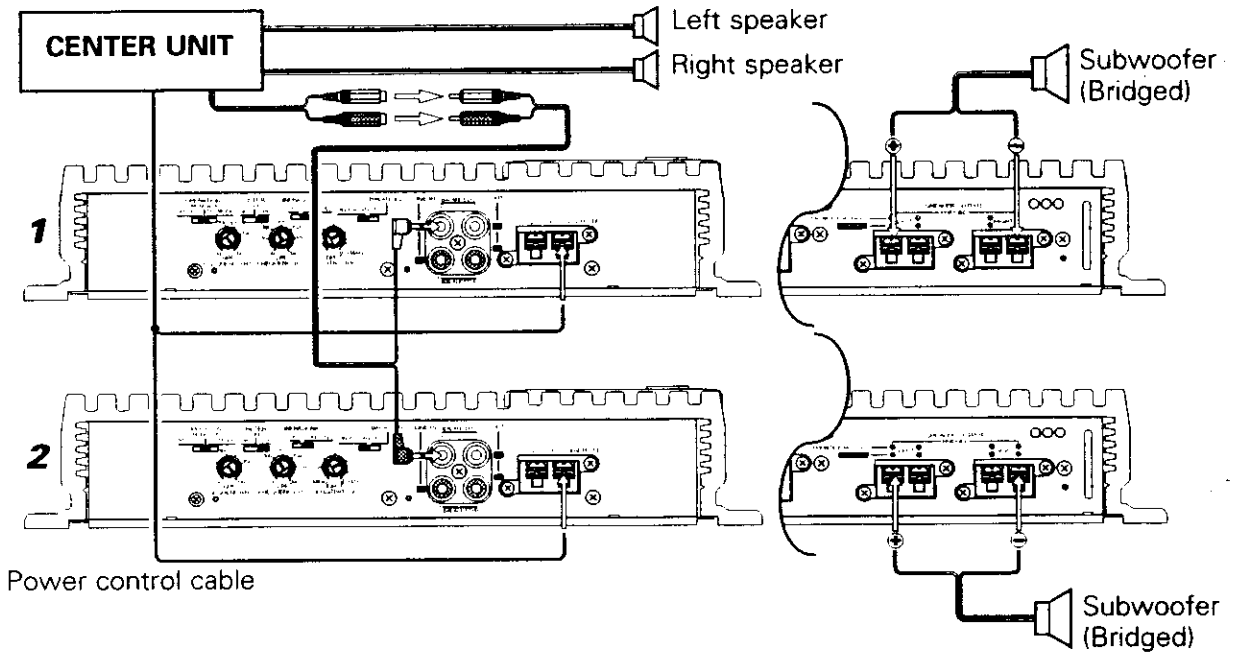

Power control cable

1 Switch setting

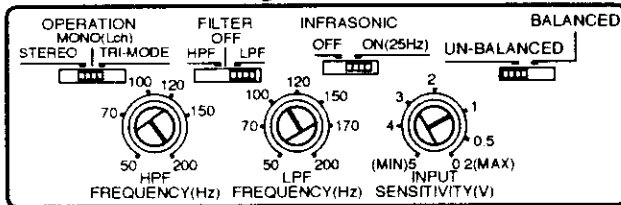

2 Switch setting

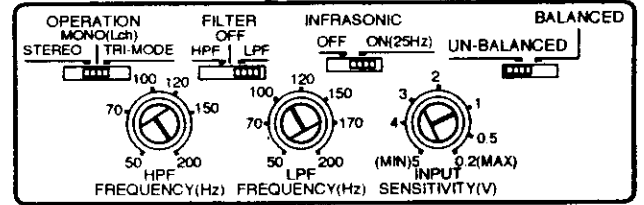

▲ CAUTION

- If you wish to bridge-connect a speaker, the speaker impedance must be no less than 4 ohms. Connecting a speaker with an impedance lower than 4 ohms may damage the unit.
- The rated input of the speakers used should not be smaller than the rated output of the amplifier. Otherwise malfunction may result. Be specially careful when using the bridge connection.
- When installing two amplifiers, connect a power tune-up cable to each amplifier to avoid exceeding the cable capacity.

System examples

■ Tri-mode

With the KAC-PS300T/PS200T, a subwoofer can be added easily to the speaker system by making use of the properties of coils and capacitors. This mode of operation is called Tri-mode.

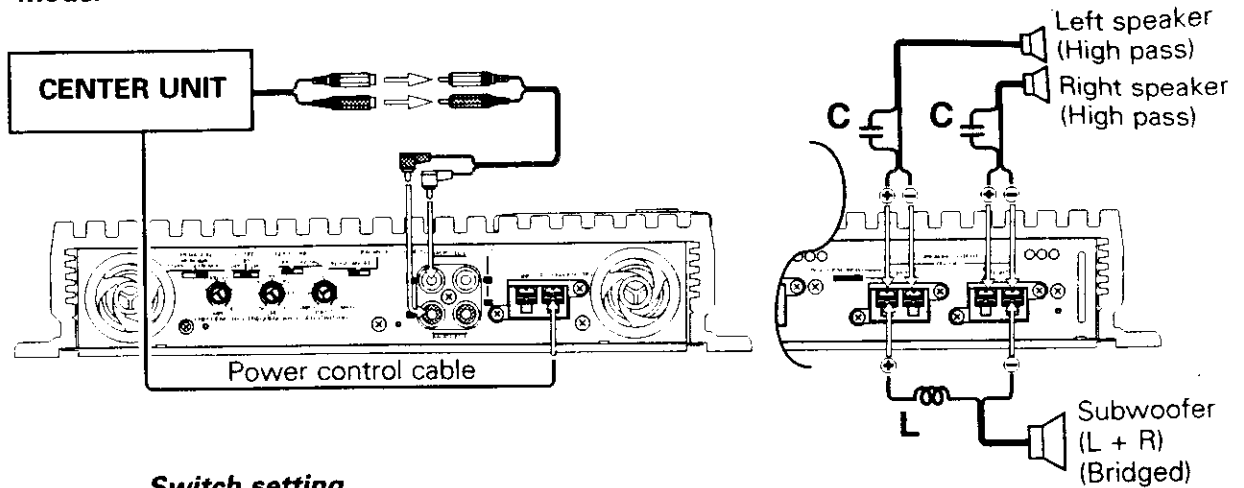

Switch setting

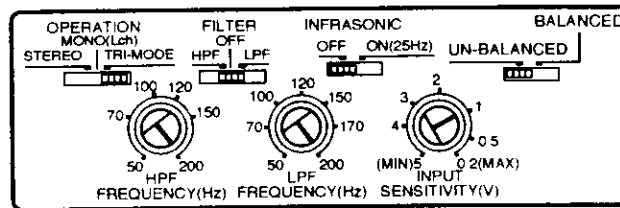

● Principle of Tri-mode

Method of frequency band division using a coil and capacitor...in case of 6dB/oct. slope

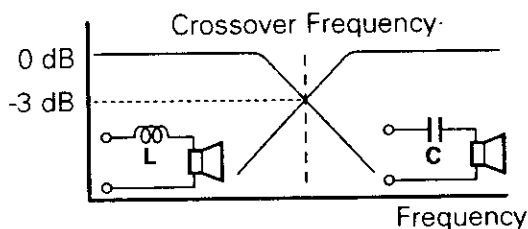

Coil (L): Passes low frequencies and blocks high frequencies. (Low pass)

Capacitor (C): Passes high frequencies and blocks low frequencies. (High pass)

$$C = \frac{159000}{f_c \times R} (\mu F)$$

f_c = Cut of Frequency (Hz)

$$L = \frac{159 \times R}{f_c} (mH)$$

R = Speaker Impedance (Ω)

● Example:

When it is required to set a crossover frequency of 120 Hz using speakers with an impedance of 4 ohms.

Prepare commercially-available coil and capacitor with the closest ratings to the results calculated from the formula above. The capacitor rating should be as close as possible to 331.25 (μF) and the coil rating should be as close as possible to 5.3 (mH).

▲ CAUTION

If you wish to bridge-connect a speaker, the speaker impedance must be no less than 4 ohms. Connecting a speaker with an impedance lower than 4 ohms may damage the unit.

Full-range 2-channel + Subwoofer (80 Hz) system (balanced)

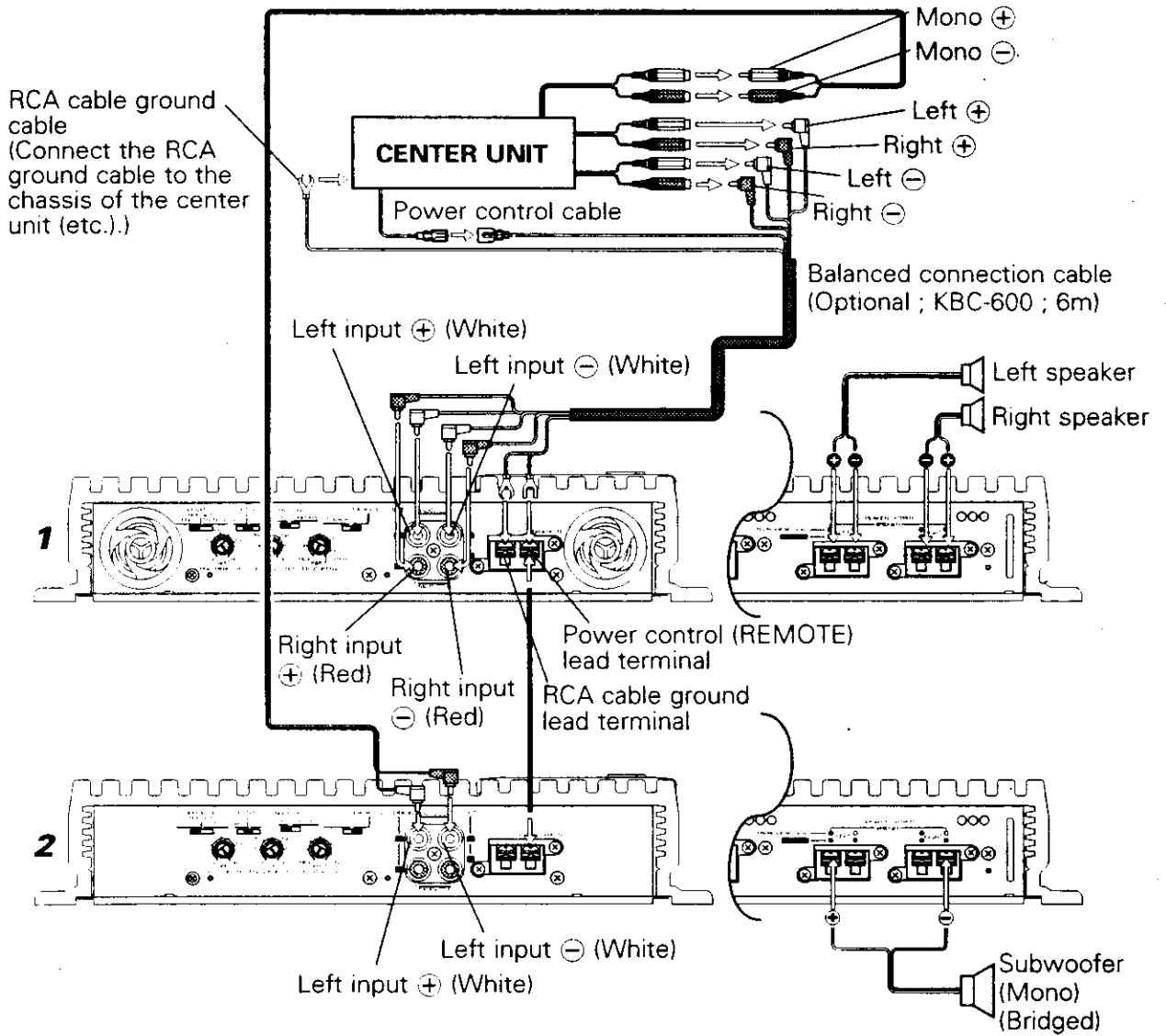

1 Switch setting

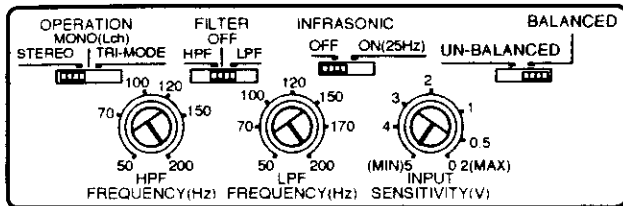

2 Switch setting

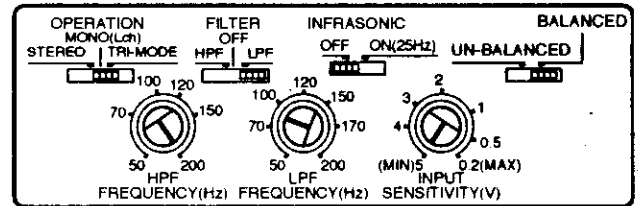

Protection function

■ Power indicator:

This indicator lights in red when the power is switched on.

If the power indicator does not light up or lights in green when the power is switched on, the protection function may be activated: Check to see if there is any trouble with the unit.

Power indicator

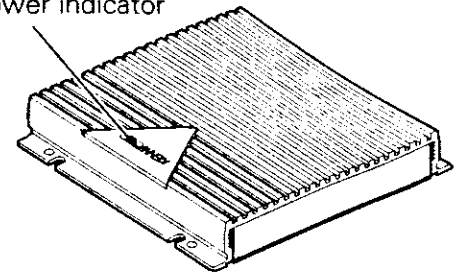

■ The protection function activates in the following situations:

This unit incorporates a protection function which protects the main unit and speakers from troubles. The unit stops to function when the protection function is activated.

• If the POWER INDICATOR lights in green:

- When a speaker cable may be short-circuited.
- When a speaker output contacts ground.
- When the temperature of internal parts exceeds 120°C (248°F)
- When the unit malfunctions and a DC signal is sent to the speaker output.

• If the POWER INDICATOR does not light up:

- When a ground cable of the center unit (cassette receiver, CD receiver, etc.) or this unit is not connected to a metal part serving as an electrical ground passing electricity to the battery's minus ⊖ terminal.

Troubleshooting guide

Often, what appears to be a malfunction is due to user error. Before calling for service, please consult the following table.

Symptom	Cause	Remedy
No sound. (No sound from one side.)	<ul style="list-style-type: none"> • Input (or output) cables are disconnected. • Protection circuit may be activated. • The fuse may be blown because the volume was too high. 	<ul style="list-style-type: none"> • Connect the input (or output) cables. • Check connections by referring to "Protection function". • Replace the fuse with a new fuse and use a lower volume.
The output level is too small (or too large).	The input sensitivity adjusting control is not set to the correct position.	Adjust the control correctly referring to "Controls".
The sound quality is bad. (The sound is distorted.)	<ul style="list-style-type: none"> • The speakers cable are connected with wrong ⊕ / ⊖ polarity. • A speaker cable is pinched by a screw in the car body. • The switches may be set improperly. 	<ul style="list-style-type: none"> • Connect them properly checking the ⊕ / ⊖ of the terminals and cables well. • Connect the speaker cable again so that it is not pinched by anything. • Set switches properly by referring to "Operation" and "System examples".

